



RESEARCH ARTICLE

STUDY OF THERMO MECHANICAL CHARACTERISATION OF TOOL GEOMETRIES ON FRICTION STIR WELDING

*¹Muruganandam, D., ²Vasanth, A., ²Prashanth, M.S., ²Dinesh Kumar, C. and ²Venkataramanan, M.

¹Department of Production Engineering, Sri Sairam Engineering College, Chennai, India

²Department of Mechanical Engineering, Anand Institute of Higher Technology, Chennai, India

ARTICLE INFO

Article History:

Received 19th December, 2015

Received in revised form

25th January, 2016

Accepted 07th February, 2016

Published online 31st March, 2016

Keywords:

Friction Stir Welding,
Heat generation, Heat flux,
Deformation, Tool geometry.

ABSTRACT

A numerical model is developed to predict the material deformations and temperature histories in the friction stir welding (FSW) process. Based on the numerical analysis, the effects of the welding parameters on material deformation and temperatures are investigated for plain cylindrical and drill tool geometries. A numerical result predicts that the temperature can be increased with the increase of the rotating speed on the FSW process. In the same way the increase in the weld speed can also lead to the tangible increase of the input power. When the rotating speed becomes higher, the welding speed must be increased simultaneously to avoid any possible welding defect. The model shows that the heat is generated on the regions of the shoulder, lateral surface of pin and tip of the pin. The predicted high temperature exists on the shoulder surface. The temperature variation is analysed for the three different tool geometries and base metals using ANSYS 14. The temperature field and predicted by the simulation method are in good agreement with the results obtained by the ANSYS 14. As per the deformation analysis during the first impact of pin the drill tool geometry obviously got more deformation and there by results in increment of total heat flux.

INTRODUCTION

The friction stir welding (FSW) technique was invented by The Welding Institute (TWI) in 1991 (Thomas *et al.*, 1991). Since then, the material flow mechanism during welding and the microstructures of the welds have been discussed vigorously. This new welding technology has been applied to aluminum products in various industrial fields, e.g. automobile and aircraft industries (Brooker *et al.*, 2000; Colligan *et al.*, 2003; Williams, 2001; Kakimoto, 2005), due to the demands for lightweight parts and environmental protection. Friction stir welding is a relatively simple process as shown in Fig.1. Friction stir welding has a wide application potential in ship building, aerospace, automobile and other manufacturing industries. In the recent past, a few research activities have been developed on the numerical simulation of FSW processes. Thermal models, taking into account the heat generated by both friction forces work and the material deformation one, have been proposed (Song and Kovacevic, 2003; Schmidt *et al.*, 2004; Chao *et al.*, 2003) trying to highlight the temperature distributions nearby the rotating pin. Song and Kovacevic have modeled the heat transfer in FSW using the finite difference method (Song and Kovacevic, 2003; Song and Kovacevic, 2002). Khandkar *et al.* (Khandkar *et al.*, 2003; Khandkar *et al.*, 2006) introduced a model of heat input based on the torque of the FSW tool that they then successfully utilized to model the temperature history of friction stir welded AA6061-T651 plate.

Utilizing a three-dimensional visco-plastic model, Ulysee (Ulysee, 2002) studied the impact of varying weld parameters on the temperature distribution in a AA7050-T7451 plate. Frigaard *et al.* (Frigaard *et al.*, 2001) developed a finite difference thermal model for a moving heat source and correlated the predicted temperature profile with the measured temperature profile for friction stir welded AA6082-T6 and AA7108-T79 extrusions. The model developed by Chen and Kovacevic (Chen and Kovacevic, 2004) uses the commercial FEM software ANSYS. A thermo-mechanically coupled Lagrangian finite element model, incorporating temperature and multi linear strain hardening, is used for the three-dimensional modeling of the solid structures. Gould and Feng (Gould and Feng, 1998) proposed a simple heat transfer model for predicting the temperature distribution in the workpiece of the FSW. Midling (Midling, 1999), Russell and Sheercliff (Russell and Sheercliff, 1999) investigated the effect of tool shoulder material and pin tool on heat input during the FSW. When modeling FSW temperature fields, it can be important to know the power of the heat source (Lambrakos *et al.*, 2003). The heat transfer process during the tool penetration period cannot be modeled if the heat input from the pin is not included. Moreover, the initial field is very important in a transient heat transfer model, especially for modeling the preheat effects of laser-assisted preheated FSW (Kohn, 2002). Colegrave (Colegrave, 2000) uses an advanced analytical estimation of the heat generation for tools with a threaded tool pin to estimate the heat generation. Schmidt *et al.*, 2004 presented analytical equations for heat generation at the tool-

*Corresponding author: Muruganandam, D.,
Department of Production Engineering, Sri Sairam Engineering
College, Chennai, India.

workpiece interface and the heat generated by the pin taking sliding/sticking contact conditions into consideration. However, these literature studies is not correlated the thermal history analysis with deformation effect. This paper is concerned to develop the numerical model on heat generation of tool geometry and the effect of heat flux due to the formation of deformation that is affected during its initial kissing bond.

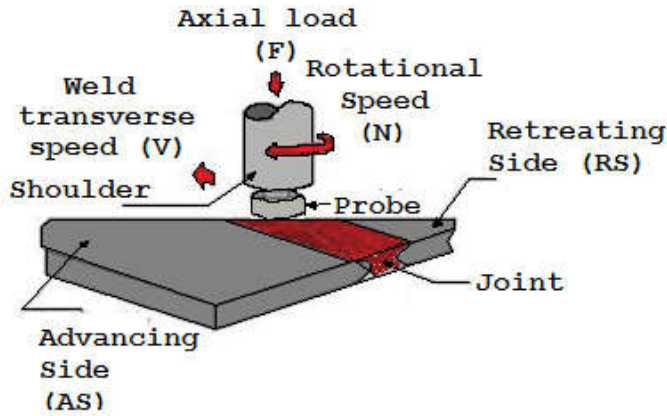

Figure 1. Schematic illustration of Friction Stir Welding

Numerical modeling

It is obvious that experimental work without the knowledge of numerical analysis will be of costly. In accordance to literature survey, the heat generation plays a major role on the strength of Friction Stir Welded joint. In this paper, numeric model of heat generation is developed for cylindrical tool geometry and the correlated temperature distribution is also analysed with ANSYS 14. In FSW process compared to the rotational speed, mechanical energy due to transverse movement is negligible with respect to the unit time and transverse movement is not considered. It is assumed on this analytical model that the heat generation phenomenon does not include non-uniform distribution. The heat generation on cylindrical M2 probe is considered on the shoulder contact surface, side of the probe and tip of the probe.

The heat generation on the shoulder (Q_{Sh}):

$$Q_{Sh} = \int_0^{2\pi} \int_{R_p}^{R_s} \omega \tau_{contact} r^2 dr d\theta$$

$$= \frac{2}{3} \pi \omega \tau_{contact} (R_s^3 - R_p^3) \quad \text{-----(1)}$$

The heat generation on the side of the probe ($Q_{Side\ probe}$):

$$Q_{probe-side} = \int_0^{2\pi} \int_0^{H_p} \omega \tau_{contact} r^2 d\theta dr$$

$$= 2 \pi \omega \tau_{contact} R_p^2 H_p \quad \text{-----(2)}$$

The heat generation on the tip of the probe ($Q_{Side\ probe}$):

$$Q_{probe-tip} = \int_0^{2\pi} \int_0^{R_p} \omega \tau_{contact} r^2 dr d\theta$$

$$= \frac{2}{3} \pi \omega \tau_{contact} R_p^3 \quad \text{-----(3)}$$

These three heat generations are contributed to predict the total heat generation at contact surface.

$$Q_{total} = \frac{2}{3} \pi \omega \tau_{contact} (R_s^3 + 3R_p^2 H_p) \quad \text{-----(4)}$$

The contact status is affected by sticking and sliding. The material flow mechanism is shearing the bonds of similar/dissimilar material and yields to rebond with each other. To accommodate the bonding the contact shear stress is assumed as follows

$$\tau_{contact} = \tau_{yield} = \frac{\sigma_{yield}}{\sqrt{3}}$$

The Q_{total} on equation (4) will be modified with this yield condition for the sticking condition on contact surface.

$$Q_{total, sticking} = \frac{2}{3} \pi \omega \frac{\sigma_{yield}}{\sqrt{3}} (R_s^3 + 3R_p^2 H_p) \quad \text{-----(5)}$$

After the sticking condition, due to the translation of tool the contact surface is getting sliding condition. During sliding friction is developed on the contact surface, the Coulomb's friction law describes the shear stress.

$$\tau_{contact} = \tau_{friction} = \mu P$$

Thus for the sliding condition, the total heat generation is given by

$$Q_{total, sliding} = \frac{2}{3} \pi \omega \mu P (R_s^3 + 3R_p^2 H_p) \quad \text{-----(6)}$$

This is counterbalanced by the additional plastic dissipation due to material deformation.

$$Q_{total, FSW} = \delta Q_{total, sticking} + (1 - \delta) Q_{total, sliding}$$

$$= \frac{2}{3} \pi \omega (\delta \tau_{yield} + (1 - \delta) \mu P) (R_s^3 + 3R_p^2 H_p) \quad \text{-----(7)}$$

Where, δ - contact state variable (dimensionless slip rate)

τ_{yield} - yield shear stress at welding temperature

ω - angular rotation speed

The dimensionless slip rate varies between values 0 to 1.

When $\delta = 0$, sliding will occur and When $\delta = 1$, sticking will occur.

Heat generation ratio's are calculated for the cylindrical pin dimensions $R_s = 9.5$ mm, $R_p = 4.5$ mm, $H_p = 5.8$ mm.

$$(H.G.R.)_{shoulder} = \frac{Q_{Sh}}{Q_{total}} = \frac{R_s^3 - R_p^3}{(R_s^3 + 3R_p^2 H_p)}$$

$$= 0.633$$

$$(H.G.R.)_{probe-side} = \frac{Q_{probe-side}}{Q_{total}} = \frac{3R_p^2 H_p}{(R_s^3 + 3R_p^2 H_p)}$$

$$= 0.2913$$

$$(H.G.R.)_{probe-tip} = \frac{Q_{probe-tip}}{Q_{total}} = \frac{R_p^3}{(R_s^3 + 3R_p^2H_p)}$$

$$= 0.075$$

The M2 tool steel is taken as material for manufacturing the Friction Stir Weld (FSW) tool. S. Pereyra *et al.*, analysed the various weld Parameters, developed a numerical model for heat transfer and material flow models. For the current analysis the convective heat transfer coefficient is assigned as 10 W/m² K as per his developed model (Pereyra *et al.*, 2014). According to Fig. it is found that the contact temperatures on Aluminium plates FSW are varies from 300 to 430⁰ C. This temperature variation account for the base metal and the current analysis deals with the tool temperature variation. The pin surface temperature is assigned as 200⁰ C and shoulder temperature as 300⁰ C.

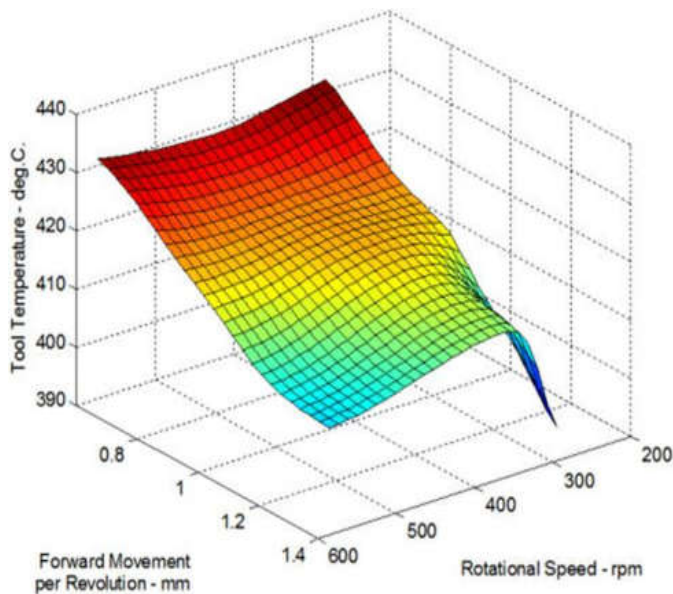
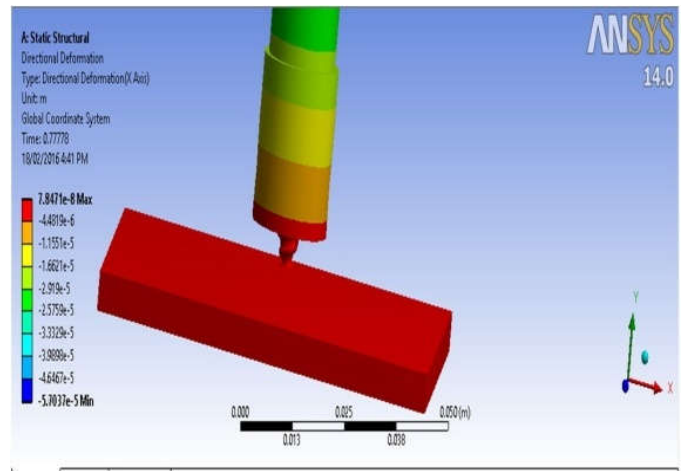
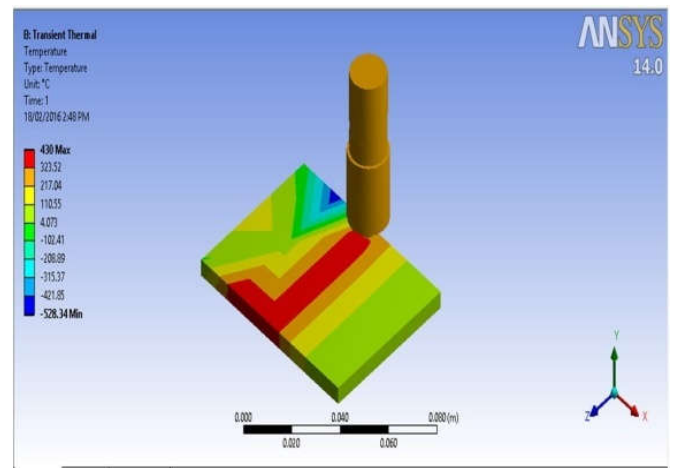

Figure 2. Model predicted tool temperature in a Friction Stir Welding tool during the welding of aerospace grade aluminium plates. Via the developed models the system can ‘map’ process conditions and internal process variables to the performance of the material. (Panoutsos and Mahfouf, 2010)



(b) Drill tool profile

Figure 3. ANSYS analysis for deformation for different tool geometry: (a) Cylinder and (b) Drill tool profile



(a) Cylindrical pin profile

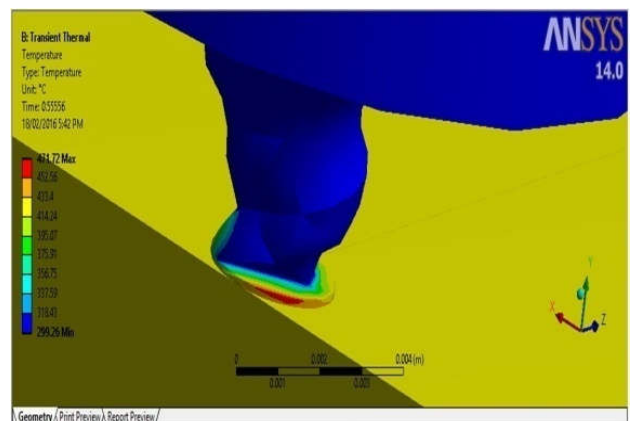

(b) Drill tool profile

Figure 4. ANSYS analysis for transient state heat flux for different tool geometry: (a) Cylinder and (b) drill tool profile

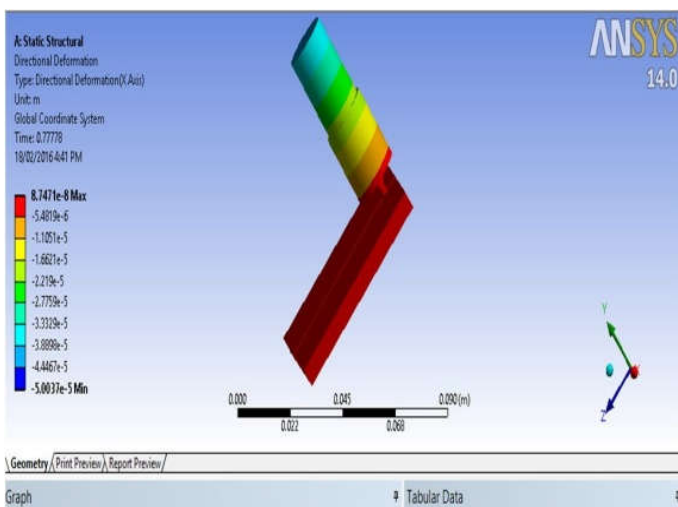

(a) Cylindrical pin profile

Figure 3 shows the comparison of maximum and minimum deformation by (a) cylindrical pin profile geometry and (b) drill tool profile geometry. It is evident that both pin profiles attains the maximum deformation on shoulder that in tends the maximum heat generation will be at shoulder. For drill pin

profile the maximum deformation is comparatively low. So the temperature distribution on Figure 4 (b), drill tool profile is considered only for kissing bond. It is evident from the Figure 4(a) of ANSYS 14 for cylinder profile that the maximum temperature exists on nugget zone. Even the heat flux also spreaded on the base plate's remaining zones on the first impact of kissing bond. The mesh element size for all the tool geometries is taken as 3×10^{-3} m. The contact surface are assigned with fine meshing. It is clear that the tool pin profile of cylinder geomtry follows a maximum heat flux dissipation on shoulder, then pin-side and pin-tip surfaces. However the drill pin reacts indifferently. The drill pin having maximum temperature distribution at kissing bond itself. According to the ANSYS analysis, the cylinder tool geometry make the heat generation maximum not only on shoulder it also have the heat distribution shared by pin side surface as well as pin tip. As per deformation, the deformation values are maximum during first impact of kissing bond.

Conclusion

The numerical equations developed predicts the heat generation ratio will be more on tool shoulder. Also the drill pin gets less heat distribution on shoulder and more on the probe side according to deformation theory. However the ANSYS results shows the temperature distribution gets maximum values on shoulder surface for the both tool profiles. But the drill pin have the maximum heat flux on probe tip. The deformation analysis concludes that the drill pin will effects more heat flux due to higher values of deformation on initial kissing bond itself. The drill pin can be concluded as the better choice for the Friction Stir Welding as per this analysis.

REFERENCES

- Brooker, M.J., Van Deudekom, A.J.M., Kallee, S.W. and Sketchley, P.D. 2000. Applying friction stir welding to ariane 5 main motor thrust frame, in: Proceedings of the European Conference on Spacecraft Structures, Materials and Mechanical Testing, Noordwijk, The Netherlands, 29 November–1 December, 2000, pp. 507–511.
- Chao, Y.J., Qi, X. and Tang, W. 2003. Heat transfer in friction stir welding experimental and numerical studies, *Trans. ASME* 125, 138–145.
- Chen, C. and Kovacevic, R. 2004. Thermomechanical modelling and force analysis of friction stir welding by the finite element method, *Proc. Inst Mech. Eng., Part C: J. Mech. Eng. Sci.* 218 (5), 509–520.
- Colegrove, P. 2000. Three-dimensional flow and thermal modeling of the friction stir welding process, in: Proceedings of the Second International Symposium on Friction Stir Welding, Sweden.
- Colligan, K.J., Konkol, P.J., Fisher, J.J. and Pickens, J.R. 2003. Friction stir welding demonstrated for combat vehicle construction, *Welding Journal*, 82, 34–40.
- Frigaard, O., Grong, O. and Midling, O.T. 2001. A process model for friction stir welding of age hardening aluminum alloys, *Metallurgical and Materials Transactions A* 32 (5), 1189–1200.
- Gould, J. and Feng, Z. 1998. Heat flow model for friction stir welding of aluminum alloys, *J. Mater. Process. Manuf. Sci.* 7, 185–194.
- Kakimoto, H. 2005. Study on application of FSW to aircraft, *Journal of the Japan Society for Technology of Plasticity* 46 939–943.
- Khandkar, M.Z.H., Khan, J.A., Reynolds, A.P. 2003. Predictions of temperature distribution and thermal history during friction stir welding: input torque based model, *Science and Technology of Welding and Joining* 8 (3), 165–174.
- Khandkar, M.Z.H., Khan, J.A., Reynolds, A.P. and Sutton, M.A. 2006. Predicting residual thermal stresses in friction stir welded metals, *Journal of Materials Processing Technology* 174, 195–203.
- Kohn, G. 2002. Laser-assisted friction stir welding, *Welding Journal* Feb, 46–48.
- Lambrakos, S., Fonda, R., Milewski, J. and Mitchell, J. 2003. Analysis of friction stir welds using thermocouple measurements. *Science and Technology of Welding & Joining* 8, 385–390.
- Midling, O.T. 1999. Effect of tool shoulder material on heat input during friction stir welding, in: Proceedings of the First International Symposium on Friction Stir Welding, Thousands Oaks, CA, USA, June 14–16.
- Panoutsos, G. and Mahfouf, M. 2010. “Neural-Fuzzy Modelling Framework Based on Granular Computing: Concepts and Applications”, *Fuzzy Sets and Systems*, 161(21). pp.2808-2830.
- Pereyra, S., Lombera, G.A., Frontini, G. Urquiza, S.A. 2014. “Sensitivity Analysis and Parameter Estimation of Heat Transfer and Material Flow Models in Friction Stir Welding”, *Materials Research*, 17(2), 397-404.
- Russell, M.J. and Sheercliff, H.R. 1999. Analytic modeling of microstructure development in friction stir welding, in: Proceedings of the First International Symposium on Friction Stir Welding, Thousands Oaks, CA, USA, June 14–16.
- Schmidt, H., Hattel, J. and Wert, J. 2004. An analytical model for the heat generation in friction stir welding, *Model. Simulat. Mater. Sci. Eng.* 12, 143–157.
- Schmidt, H., Hattel, J. and Wert, J. 2004. An analytical model for the heat generation in friction stir welding, *Model. Simul. Mater. Sci. Eng.* 12, 143–157.
- Song, M. and Kovacevic, R. 2002. Numerical simulation and experimental analysis of heat transfer process in friction stir welding process, *Proceeding of Institution of Mechanical Engineers, Part B, Journal of Engineering Manufacture*, 216 (12), 73–85.
- Song, M. and Kovacevic, R. 2003. Thermal modeling of friction stir welding in a moving coordinate system and its validation, *Int. J. Mach. Tools Manufact.* 43, 605–615.
- Song, M. and Kovacevic, R. 2003. Thermal modeling of friction stir welding in a moving coordinate and its validation, *International Journal of Machine Tool and Manufacturing*, 43 (6). 605–615.
- Thomas, W.M., Nicholas, E.D., Needham, J.C., Murch, M.G., TempleSmith, P. and Dawes, C.J. 1991. The Welding Institute, TWI, International Patent Application No. PCT/GB92/02203 and GB Patent Application No. 9125978.8.
- Ulysee, P. 2002. Three-dimensional modeling of the friction stir-welding process, *International Journal of Machine Tools and Manufacture* 42, 1549–1557.
- Williams, S.W. 2001. Welding of airframes using friction stir, *Air & Space Europe* 3, 64–66.