



RESEARCH ARTICLE

ANALYSIS AND RESEARCH ON DYNAMIC CHARACTERISTICS OF RAILWAYWAY VEHICLE BRAKING SYSTEM

*Jiaying, L.I.

Huanghai University, Qingdao, China

ARTICLE INFO

Article History:

Received 17th January, 2019

Received in revised form

09th February, 2019

Accepted 11th March, 2019

Published online 30th April, 2019

Keywords:

Creep, Temperature field, Computer, Anti-lock braking system, brake.

*Corresponding author: Jiaying, L.I.

ABSTRACT

The creep phenomenon will inevitably occur in the course of railway vehicles traveling. By solving the creep mathematical model, the relationship among wheel-railway adhesion coefficient, vehicle speed and creep rate is obtained. On this basis, the mathematical model of ABS and AMESim simulation model are established, and the simulation and analysis are completed under the conditions of track drying and wetting. The temperature field of disc brake is analyzed based on ABAQUS. The boundary condition of finite element model is defined and the load is consistent with the simulation result of AMESim. The research shows that the anti-lock braking system (ABS) has a good application effect, which can keep the vehicle braking in the optimal creep state, reduce the braking distance and time, and improve the anti-thermal attenuation ability of the brake disc. The application of anti-lock braking function in hydraulic braking system is of great significance to the improvement of railway vehicle transportation capacity.

INTRODUCTION

Railway vehicle is one of the most widely used transportation equipment, which has better flexibility and controllability. With the great improvement of transportation efficiency, the transportation capacity of railway vehicles (transportation distance, carrying capacity, carrying speed, working inclination, etc.) gradually increases, which has a good role in promoting the efficiency and economic benefits of transportation, but also puts forward higher requirements for the safety and reliability of the braking system. The brake needs to satisfy the following requirements: (1) the braking moment is controllable; (2) the fixed-point parking ability; (3) the reliability of power-off braking; (4) the zero-speed maintenance ability of the braking moment when heavy load starts. The traditional braking mode of railway vehicles is brake shoe braking, which has the advantages of large braking moment and simple operation. However, its braking response is slow, and it is prone to lock-in and thermal attenuation, which limits the improvement of carrying capacity and speed to a certain extent. With the development of braking technology, hydraulic disc brake has gradually been widely used. It has good linearity of braking moment, strong heat dissipation ability and rapid braking. In order to improve the braking capacity of railway vehicles, a disc brake with MK20 anti-lock brake system (ABS) is studied in this paper. Using AMESim and ABAQUS to simulate the braking effect, ensure the reliability of braking work, and effectively improve the transportation capacity, which is of great significance for safe and efficient production.

Analysis of wheel-rail creep

Creep principle: As shown in Fig.1, under the action of pressure, an elliptical contact surface will be formed between

the wheel and the steel track. When the vehicle is running normally, the wheel-rail rolling state is pure. There is no tangential force in the contact spot, and the in-plane linear speed is the same. When the wheel is braking, the tangential force will appear on the contact surface under the braking moment T_0 . With the elastic sliding, the contact surface is divided into two parts: the adhesive zone and the sliding zone. At this time, the linear velocity of the contact surface is no longer the same. The elastic slip produced by braking process is creep. The tangential force on the contact surface is called creep force. When creep force increases to a certain value, large displacement slip will occur. When braking, creep degree can be expressed by creep rate S :

$$S = \frac{v - \omega R}{v} \quad (1)$$

Where v is the tramcar speed, unit of m/s. ω is the tramcar wheel speed, unit of rad/s. R is the wheel rolling radius, unit of m.

Wheel-rail creep model: The creep characteristic between wheel and rail has an important influence on braking stability. In braking state, the adhesion between wheel and rail is directly related to creep effect. The relationship between creep rate and adhesion coefficient can express the braking state to a certain extent. Generally, the linear model based on Kalker coefficient is used to solve the wheel-rail adhesion problem, but this model is only applicable to the slip state, and cannot solve the large displacement lock-in sliding problem. Aiming at the braking condition of traction slip, Oldrich Polach mathematical model is used to characterize the creep model. Under this mathematical model, the mathematical calculation program is compiled by using MATLAB software. The relationship between wheel-rail adhesion coefficient, vehicle speed and creep rate under dry and wet track conditions is solved and drawn as shown in Fig.2 and Fig.3.

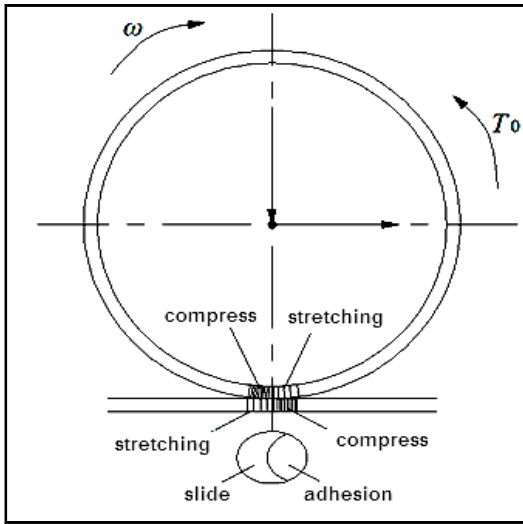

Fig.1 Schematic diagram of wheel-rail contact state

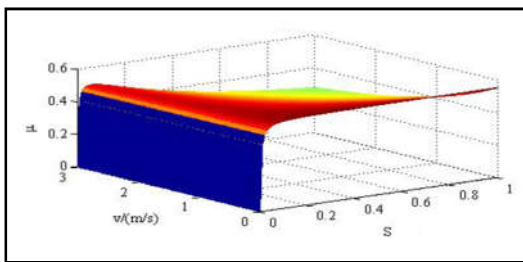

Fig.2 Dry track condition result

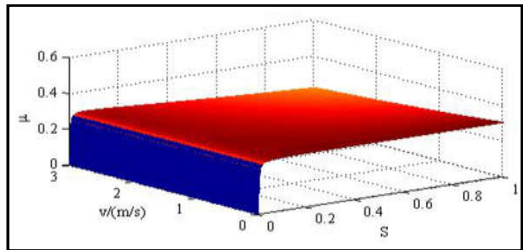
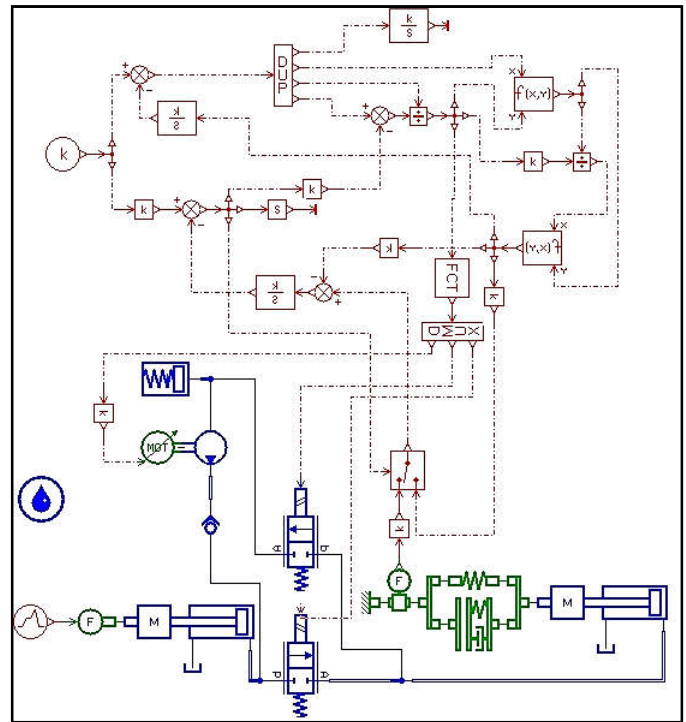

Fig.3 Wet track condition result

Numerical Simulation of ABS

Establishment of model: In order to study the influence of anti-lock braking system on vehicle braking performance, AMESim simulation software is used to calculate creep rate and braking distance in braking. Before numerical simulation, it is necessary to establish the mathematical model of anti-lock braking. In order to facilitate the analysis, the single wheel-rail model is taken as the research object in this paper. The traction force is equalized, and the air resistance and the moment of inertia of the moving mechanism are neglected. A numerical simulation model based on AMESim is established as shown in Fig.4. In the simulation model, integral and differential function modules are synthetically used to process the data. The integral module calculates the driving distance by dividing the instantaneous speed, and the differential module obtains the angular acceleration by dividing the wheel speed. In the pressure regulating unit of the anti-lock brake model, the brake main cylinder simulation model uses a single hydraulic cylinder module to simulate the high-pressure chamber action of the brake main cylinder, and obtains the pressure of the brake main cylinder through a segmented signal source. In the controller unit, the value of creep rate is judged by the FCT function module in the signal library, and the control instructions are issued according to the judgement results. In

order to compare and analyze the effect difference between conventional braking and anti-lock braking, the pressure regulating unit and controller unit in the anti-lock braking model are omitted, and the conventional braking model is established.



Analysis of simulation results: Through numerical simulation, creep rate and braking distance under different conditions are obtained as shown in Fig. 5 and Fig. 6, respectively.

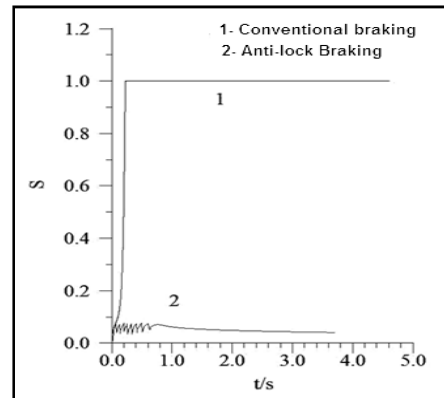

Fig. 5. Simulation result in dry track condition

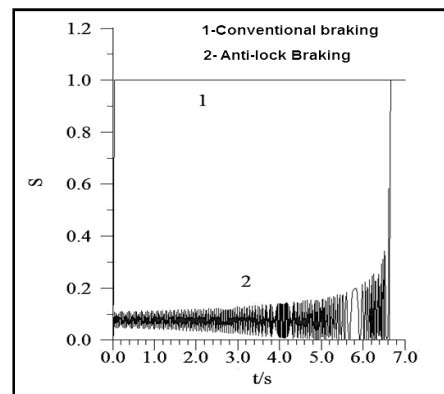

Fig. 6. Simulation result in wet track condition

Fig. 5 and Fig. 6 show that: (1) under the action of conventional braking system (without anti-lock), a large braking moment will cause the wheel to produce a pure rolling-creeping-lock drag-slip process in a relatively short time, which will make the adhesion coefficient between wheel and rail increase sharply instantaneously, and then keep the value of 1. (2) The anti-lock braking system obviously restrains the creep phenomenon of wheel and rail, especially in dry conditions, the creep rate is always lower than 0.15, and the braking time is shorter; (3) The anti-lock braking system can effectively reduce the braking distance and braking time, especially in dry track environment, the braking performance is better. From the analysis of wheel-rail creep, it can be seen that the reduction of creep rate can effectively improve the utilization ratio of wheel-rail adhesion coefficient, thereby improving the reliability of braking system. Therefore, for the anti-lock braking system, its main function is to control the wheel-rail creep rate through the pressure regulating unit, so that it fluctuates near the optimum creep rate, so as to provide greater adhesion and improve the braking effect. Thus, under the action of MK20 anti-lock braking system, the carrying capacity can be greatly improved.

Transient temperature analysis of brake disc

Preprocessing of finite element model: In order to solve the transient maximum temperature of brake system, ABAQUS is used to simulate the transient temperature field by finite element method. The pre-processing work in the finite element model mainly includes: establishing the temperature-displacement coupling analysis step of brake, the time step is 0.001 s, and the load step is 7000; using C3D8RT hexahedron element to mesh the brake disc and disc; setting the rotational freedom of the brake disc by the way of the reference point coupling surface; defining the friction coefficient of the friction pair (related to temperature and pressure). Brake pressure, brake disc speed (equal deceleration rotation) and other parameters; set the friction contact as “hard contact” and consider the influence of thermal radiation; set the convection heat transfer coefficient, initial speed, initial temperature and other conditions. In order to ensure the accuracy of the calculation, the parameters of the boundary conditions of the finite element model are set by the data derived from the AMESim calculation results.

Result analysis: As shown in Fig. 7 and Fig.8, the temperature field cloud of brake disc decelerated to static time under conventional braking conditions. In Fig.7 and Fig.8, it can be seen that the temperature distribution on the surface of the brake disc shows obvious discontinuity under the action of the brake pad pressure; due to the small friction coefficient, the brake disc decelerates to rest for a longer time under wet conditions, so the temperature distribution is more uniform; the brake disc has a shorter braking time under the condition of track drying, but the brake pressure is higher and the peak temperature is higher. As shown in Fig.9 and Fig.10, the temperature field cloud of the brake disc decelerated to the static time under the condition of anti-lock braking. Compared with conventional braking, the brake pad pressure under anti-lock braking can be adjusted automatically according to creep rate, so the temperature distribution of the brake disc is more uniform, and the peak value of temperature is lower, which improves the thermal attenuation ability of the brake disc.

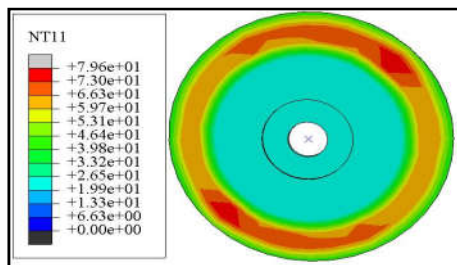

Fig.7 Conventional braking in dry condition (4.5s)

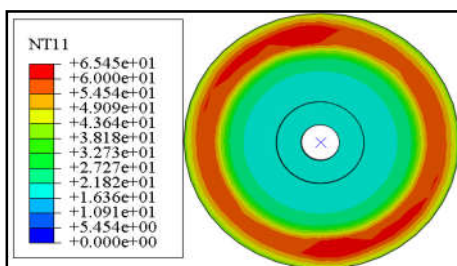

Fig.8 Conventional braking in wet condition (6.8s)

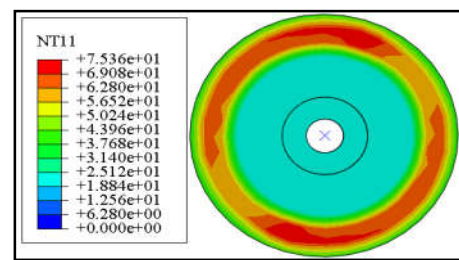

Fig. 9. Anti-lock braking in dry condition (4.5s)

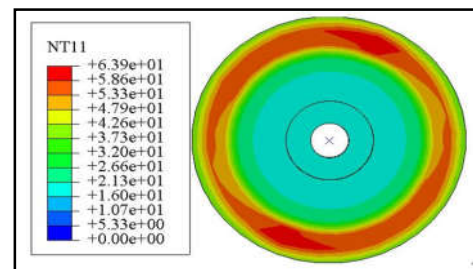

Fig. 10. Anti-lock braking in wet condition (6.8s)

Acknowledgement: The paper is supported by the Youth Talent Innovation Project (BZXYQNLG201607).

Conclusion

The braking performance of rail vehicle is very critical, so MK20 anti-lock brake system can be applied to hydraulic disc brake. In this paper, the braking system is numerically simulated by AMESim and ABAQUS. Oldrich Polach model is solved by MATLAB, and the relationship between adhesion coefficient, creep rate and tramcar speed is obtained. In addition, the temperature-displacement coupling model of the brake is established by using ABAQUS, and the transient temperature field of the brake disc under different conditions is obtained. Through the research of this subject, it can be seen that the application of anti-lock braking system can obviously improve the utilization ratio of adhesion coefficient between wheel and rail, and reduce the transient maximum temperature of brake disc.

REFERENCES

Huang, J., Kong, L.G. 2015. Temperature field and stress field analysis of disc brake. *Mechanical Design And Manufacture*, 12: 143-145.

- Sun, S.L. 2013. Research on the normal contact between wheel and rail of metro vehicles. *Urban Rail Transit Research*, 08: 39-43.
- Savitski , D., Hoepping, K. 2015. Impact of the tire inflation pressure variation on braking efficiency and driving comfort of full electric vehicle with continuous anti-lock braking system. *SAE International Journal of Passenger Cars-Mechanical Systems*, 08: 460-467.
- Voltr, P., Lata, M. 2015. Transient wheel-rail adhesion characteristics under the cleaning effect of sliding. *Vehicle System Dynamics*, 53: 605-618.
- Wang, D.F. 2012. Performance simulation and test of pneumatic brake anti-lock system for multi-axle heavy duty trucks. *Journal of Jilin University*, 42: 7-12.
- Liu, B., Guo H.B. 2015. Design of sliding mode variable structure controller for anti-lock braking system of automobiles . *Journal of Jilin University*, 33: 19-25.
- Wu, J.S. 2010. Simulation and analysis of temperature and thermal stress fields of disc brake under emergency braking conditions. *Beijing Automobile*, 06:30-33.
