



RESEARCH ARTICLE

POWER MANAGEMENT IN INTELLIGENT BASED DAILY DEMAND FORECAST

Jothi Swaroopan, N.M., Mohan Kumar, M., Sharath Kumar, D. and Hemanth, S.

Dept. of EEE, R.M.K Engineering College

ARTICLE INFO

Article History:

Received 19th December, 2017
Received in revised form
27th January, 2018
Accepted 09th February, 2018
Published online 30th March, 2018

Keywords:

Intelligent,
Demand,
Power Consumption.

ABSTRACT

The objective of the paper is to design and implementation of an intelligent device for monitoring the electrical parameters of household appliances and subsequently calculates the power consumed on daily demand prediction. The developed system is a low-cost, flexible in operation and can save electricity expense of the consumers. This system can detect the high and low voltage passing in the line as well as the short circuit by using short circuit detector. Through Wi-Fi, the information is sent to the server for informing that there is any short circuit. All data are recorded in a server to control the power and even how much load is consumed by the appliance such as light, fan.AC etc.

INTRODUCTION

Electricity is the most basic need of everyone in this modern world. Energy consumption graph is increasing day by day whereas the resources of energy are diminishing parallel [Erol-Kantarci, 2011]. Usage of power is growing drastically paving the way for energy efficient technologies and digging for renewable energy sources [Li, 2011; Andrey, 2010]. Since avoidance is better than cure awareness of energy consumption should be brought into every place before resources get quenched [Man Han, 2010; Kamat, 2011]. Industrial users consume about 37 percent of the total energy, personal and commercial transportation consumes 20 percent whereas residential appliances consume 11 percent; and commercial uses amount to 5 percent of the total energy and remaining 27 percent of the world's energy is lost in energy transmission and generation [Benzi, 2011; Kunold, 2011; Han, 2011]. The designed system will help in reducing the energy wastage by continuously monitoring and controlling the electrical appliances. In the proposed system, power consumption of devices is measured and maintained to resist the overflow of power for a particular device. The owner is alerted such that in case of short circuit, power overflow and controlling the device. Hence, it emerges as an advance technique in this real world to control their device. Accuracy power is high and time consume for measurement is less. It can be applied for industry level to control their overall device power measurement and safety can be achieved by using this process.

Drawback of Existing System

- Laziness to switch on/off home appliance power.
- No records are provided how much current is produced.

- No cost estimation.
- No exact information for power usage.
- No control of home appliance.
- No cause identification for power cut.

Proposed System

The Hardware components of the proposed components are:

- Signal conditioner
- Relay
- Current Transformer
- Potential Transformer
- ESP8266 WIFI Module
- Short circuit detector
- Microcontroller
- LCD display(16*2)
- SQL Server

Signal Conditioner

Signal conditioning can include amplification, filtering, converting, range matching, isolation and any other processes required to make sensor output suitable for processing after conditioning. Most common use is in analog- to-digital converters. Hence the ac supply cannot be given directly to the PIC microcontroller, it may damage the circuit and the required output cannot be obtained. So the input supply of 220v is converted to 5v, since the microcontroller can work only on 5v supply, this conversion process can done with the help of signal conditioner.

Proposed System

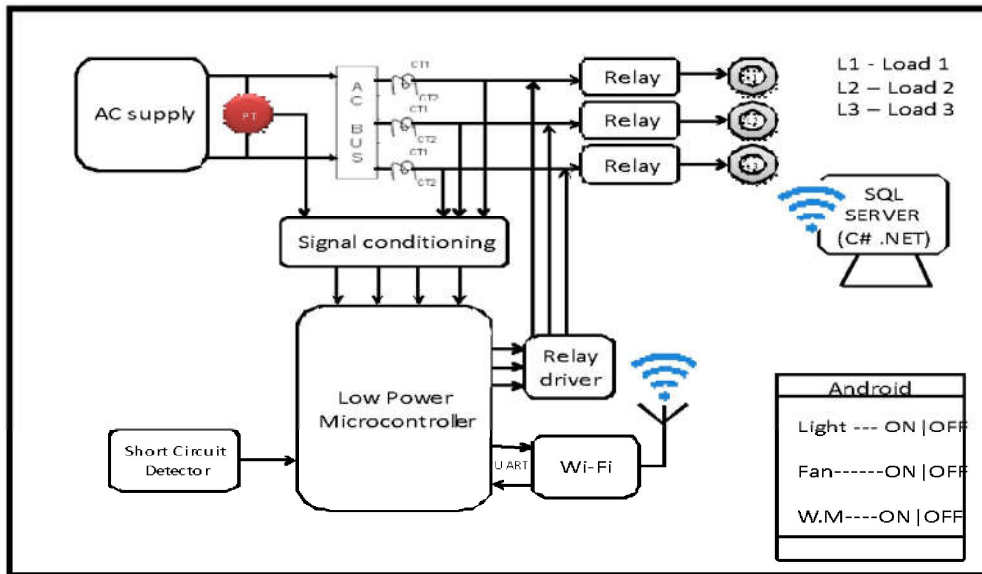
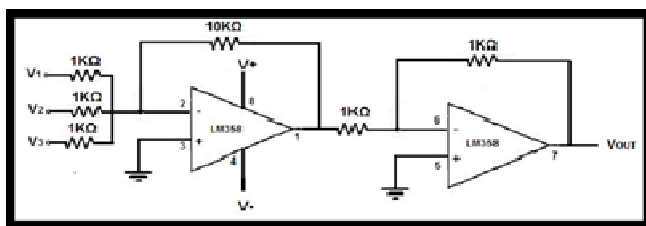

Fig. 1. Block Diagram of Proposed system



RELAY

A relay is an electromagnetic switch operated by a relatively small electric current that can turn on or off a much larger electric current. The heart of a relay is an electromagnet (a coil of wire that becomes a temporary magnet when electricity flows through it). Relays can work either as switches (turning things on and off) or as amplifiers.

Potential transformers

The potential transformer works along the same principle of other transformers. It converts voltages from high to low. It will take the thousands of volts behind power transmission systems and step the voltage down to something that meters can handle. These transformers work for single and three phase systems, and are attached at a point where it is convenient to measure the voltage.

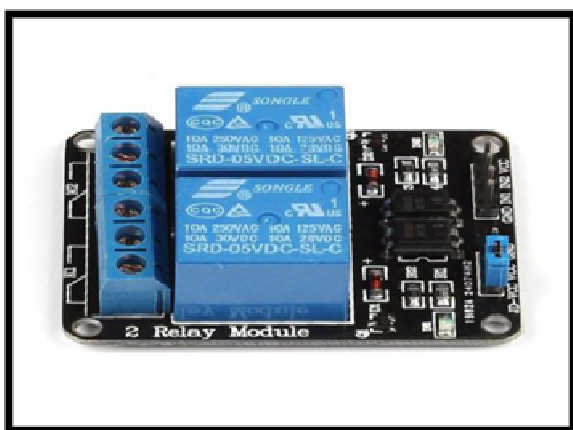

Hence, from the block diagram, relay that acts as a protective circuit for the PIC microcontroller from an ac supply.

Current Transformer

Current transformers are used extensively for measuring current and monitoring the operation of the power grid. Hence, the current transformers are connected in series with the supply terminals in order to measure the successive current and it also helps to monitor those currents.

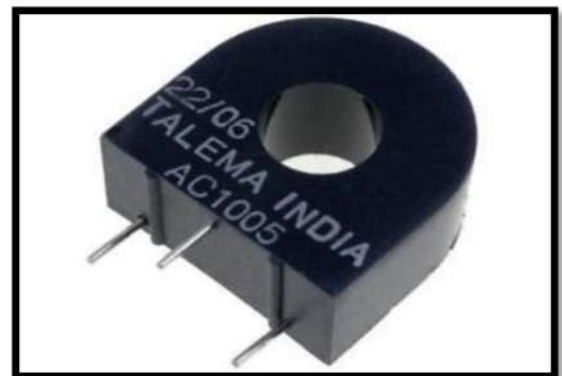

The biggest feature that a potential transformer has over regular transformers is that the voltage conversion is constant and linear. That is to say, if the first day of operation 50,000 volts is stepped to 50 volts, then on the last day of operation 50,000 steps to 50 volts. Linearity states that when the voltage drops in a linear fashion, then the stepped down voltage drops accordingly. This feature ensures that the meter will scale accordingly. The potential transformer makes the measure of very high voltages much easier.

Wifi Module

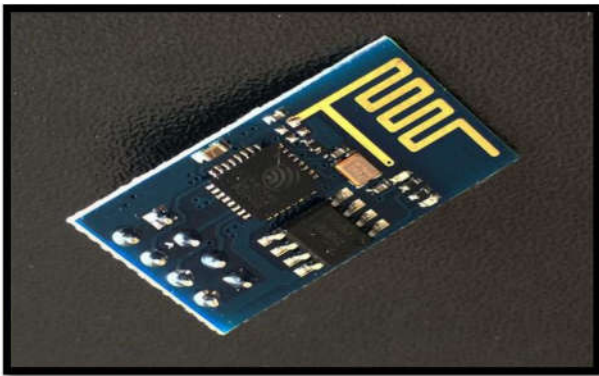

ESP8266 is WIFI module suitable for connecting to an existing microcontroller project via a UART serial connection without altering the process and function of the microcontroller. The hardware connections required to connect are almost simple and straight-forward. This module needs only 3.3 V power.

Features

- It has Integrated temperature sensor
- Power down leakage current is less than 10uA
- Integrated low power 32-bit CPU could be used as application processor
- Serial Peripheral Interface, Universal Asynchronous Receiver Transmitter
- Standby power consumption of is less than 1.0Mw

Pic Microcontroller

Peripheral Interface Controller (PIC) microcontroller chips are the world's smallest microcontrollers. Microcontrollers are designed for embedded applications that make the embedded world very simple. It includes Processor for processing, Non-volatile memory for the program (ROM or flash), Volatile memory for input and output (RAM), Clock for timer and counter and Control unit for controlling the system process. It is also called as "computer on a chip".

Reasons for Using Pic

- Variety of choices (8-bit to 32-bit)
- Affordable (Low Cost)
- Low Power
- Reasonable Size
- Convenient Packaging
- Through Hole (Dip)
- Surface Mount (SMD)

Analog to digital converter module

When configuring and using the ADC there are some functions to be considered: Port configuration, Channel selection, ADC

voltage reference selection, ADC conversion clock source, Interrupt control, Results from formatting Port configuration. The ADC can be used to convert both analog and digital signals. The ADC plays a major role in fingerprint verification process.

Lcd Display

LCD (Liquid Crystal Display) is an electronic display module which finds a wide range of applications in the digital environment for every display unit due to its uniqueness. A16x2 LCD can display 16 characters in a line of 5x7 pixel matrix each and has totally 2 lines in it. The command register stores the command instructions.

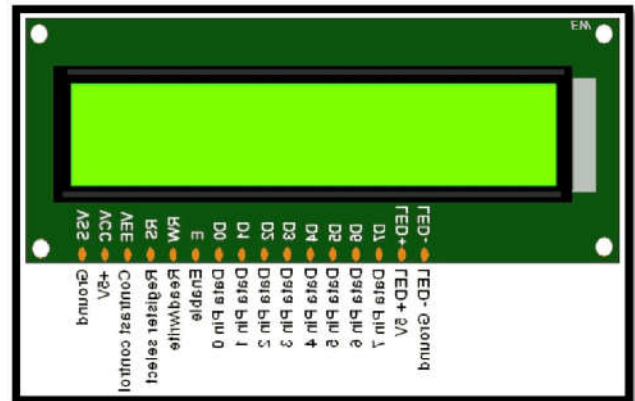

To do a predefined task like initializing the LCD for display, positioning the cursor, clearing the screen, controlling display features like brightness, contrast etc., and the instructions are given to the command registers. The data register stores the data that has to be displayed on the LCD. The LCD controller requires about 40 to 120 microseconds for writing and reading and needs 5milliseconds for other operations. LCD requires 11 Input/output supply lines of 5 Volts for 8-bit data.

SQL Server

SQL is used to communicate with a database. SQL statements are used to perform tasks such as update data on a database, or retrieve data from a database. Some common relational database management systems that use SQL are Oracle, Sybase, Microsoft SQL Server, Access, Ingres, etc. Hence the parameters of current and voltage has been measured and the obtained results are stored in a database of SQL server . The server can also be used as monitoring system, SQL server has been communicated with the help of ESP8266 Wi-Fi module .

Task of the proposed system task 1

- When the ac supply is received, the system checks the supply.
- Accordingly the system calculates the voltage and current.
- Calculates the cost of power automatically.

Task 2: Detects the cause of short through the short circuit detector.

Task 3: Some appliances have limit in usage. In order to maintain the life of the electrical appliances we limit the working of appliances.

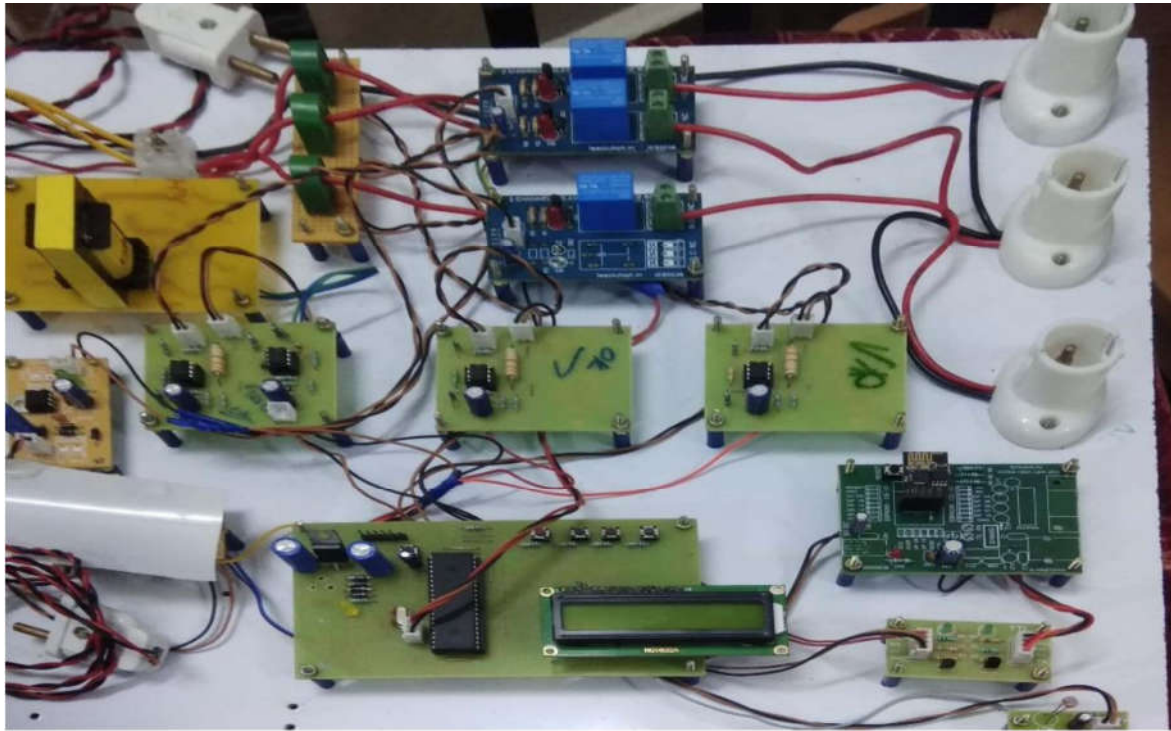

Fig. 2. Hardware setup of the proposed system

Table 1. Control Analysis of Loads

Load	Usage	Amount(Rs./day)	Margin/month	Control
AC	10000 watts	23	40000 watts	ON/OFF
FRIDGE	5000 watts	11.5	15000 watts	ON/OFF
TV	3000 watts	6.9	12000 watts	ON/OFF

Task 4: It is not necessary to be there at home. Even we are not physically present at home we can control the power supply to home appliances. We design a remote and manual control of power supply.

Task 5: All databases are recorded in a server to control the power. The recorded data can be viewed through an android app.

Advantage

- Cost estimation for every addition of unit
- Find the cause of power cut(i.e. due to short circuit or EB)
- Will be evidence in case of each appliances
- Can control the power supply automatically
- No need to be physically present at each and every room to switch off
- Can limit the usage the power
- At industrial level we can use the system to increase quality of each element
- Can control the system from anywhere at anytime

Hardware & Output

Stage 1 AC: By fixing margin amount per month to control the excess usage of energy and to save the money. If AC took Rs.1000 per month, with the help of our proposed system and by fixing marginal amount of Rs.600 and the AC consumes more than this marginal amount, get indication and also it can automatically off with timer process. Thus save the Energy and the money.

Stage 2 FRIDGE: Same function is performing in Fridge also and this system is used to improve the standard of saving energy. This method is a continuous step of monitoring the usage and collects it to data base for future enhancement.

Stage 3 TV: TV consumes less energy of 138 watts per month and it can be maintain without problems daily. If consumes more than the marginal amount, get indication and also it can automatically off with timer process. Thus save the Energy and the money. The fig. 2 shows the hardware setup of the proposed system. Table1 shows the out control analysis of different load device. The output can be shown by value of cast ,usage of current by particular element, hole control over a element is performed Indication signal by app and also manual

Conclusion

Thus the paper has built an intelligent remote electric power monitor/control system which is very easy to install and does not need additional wiring. This system enables the user to control the on/off and the power consumption remotely using wirelesstechnology. The Voltage, current and power consumed by each appliance is measured and user can also allot the certain power consumption for the appliance.

REFERENCES

- Andrey, E. and Morelli, J. 2010. "Design of a smart meter techno-economic model for electric utilities in Ontario," in Proc. IEEE- Electric Power Energy Conf., pp. 1-7.

- Benzi, F., Anglani, N., E. Bassi, and L. Frosini, "Electricity smart meters interfacing the households," *IEEE Trans. Ind. Electron.*, vol. 58, no. 10, pp. 4487-4494, Oct. 2011.
- Erol-Kantarci, M. and Mouftah, H. T. 2011. "Wireless sensor networks for costefficient residential energy management in the smart grid," *IEEE Trans. Smart Grid*, vol. 2, no. 2, pp. 314-325, Jun.2011.
- Han, J., Choi, C. S. and Lee, I. 2011. "More efficient home energy management system based on zigbee communication and infrared remote controls," *IEEE Trans. Consumer Electron.*, vol. 57, no. 1, pp. 85-89, Feb.
- Kamat, V.N. 2011. "Enabling an electrical revolution using smart apparent energy meters & tariffs," in *Proc. Annu. IEEE India Conf.*, pp. 1-4.
- Kunold, I., Kuller, M., Bauer, J. and Karaoglan, N. 2011. "A system concept of an energy information system in flats using wireless technologies and smart metering devices," in *Proc. IEEE 6th Int. Conf. Intell. Data Acquisition Adv. Comput. Syst.*, pp. 812-816.
- Li, L., Xiaoguang, H., Jian, H. and Ketai, H. 2011. "Design of new architecture of AMR system in Smart Grid," in *Proc. 6th IEEE Conf. Ind. Electron. Appl.*, pp. 2025-2029.
- Man Han, D. and Hyun Lim, J. 2010. "Smart home energy management system using IEEE 802.15.4 and zigbee," *IEEE Trans. Consumer Electron.*, vol. 56, no. 3, pp. 1403-1410, Aug.
