



RESEARCH ARTICLE

STUDY ON INTELLIGENT CONTROLLERS

***Anusha Rani, V.**

Assistant Professor, Department of Electronics and Instrumentation Engineering,
PSN College of Engineering and Technology

ARTICLE INFO

Article History:

Received 12th May, 2017
Received in revised form
02nd June, 2017
Accepted 29th July, 2017
Published online 30th August, 2017

Keywords:

Intelligent Control,
Computing, Distributed
Computing Systems.

ABSTRACT

Intelligent Control emulates the human intelligence and achieves automation in various areas of Engineering. Intelligent Controls have been used mainly in the areas of Electrical Systems; Machine Intelligence based systems like Robotics. Intelligent Control has been active in various industrial and engineering applications. There is active research in applying Intelligent Controls in distributed computing systems like web based environments. The advent of internet has changed the business models for the service providers and consumers. The Distributed Computing Systems which host various IT and business services are expected to be available with high performance and scalability to meet the desired SLAs. There is absolute necessity in predicting the future trends of the IT environments, recognize the load patterns such that the provisioning of the hardware, software resources is appropriately handled. There are research attempts to explore the applicability of intelligent control in such different areas of computing like infrastructure provisioning and Distributed Systems. In this paper we study the various Intelligent Controls and discuss the recent trends of applying intelligent controls in Distributed Systems such as Web Servers.

INTRODUCTION

Machine Intelligence is an active area of research for the last many decades. There are various technologies that have emerged such as Artificial Intelligence, Fuzzy Sets, Neural Networks. The major objective of all these technologies is to build the knowledge into a machine which emulates the behavior of human intelligence (Kevin M. Passino, 2001). Intelligent Control is successfully applied within a spectrum of industrial and engineering disciplines (Ali Zilouchian, Mo Jamshidi, 2001). There are recent research advances in investigating applicability of Intelligent Control in various areas of Computing. Mainly we observe that the target areas are Distributed Computing Systems such Web environments in improving their performance, QoS Management. The intent of intelligent control is to bring the intelligence in the control mechanisms and incorporate human expert knowledge in the computing processes. The classical feedback systems have bottlenecks to handle non-linear dynamics and variable load conditions such as web based distributed systems. Intelligent controllers have the ability to handle such challenges and in this paper we review the applicability of various intelligent controller techniques that are applied in distributed systems such web servers, data centers server allocation, admission control of servers. We also present a brief overview of some of the important Intelligent Controller techniques.

***Corresponding author: *Anusha Rani, V.**

Assistant Professor, Department of Electronics and Instrumentation Engineering, PSN College of Engineering and Technology

Intelligent Controllers

Intelligent Control is a control technique that uses various Artificial Intelligence based approaches such as neural networks, fuzzy control. In this section we discuss the most popular intelligent controls that are explored for application in the Distributed systems. There are other techniques such as Bayesian control, Genetic algorithm based controllers but not discussed in this paper.

Neural Network Controllers

Artificial neural networks are circuits, computer algorithms, or mathematical representations loosely inspired by the massively connected set of neurons that form biological neural networks. Artificial neural networks have proven useful in a variety of pattern recognition, signal processing, estimation, and control problems. The Figure 1 below shows a single neuron model which represents the biological neuron that fires when inputs (x_i) are significantly excited. The firing is defined by the activation function f . The Figure 2 shows a 3 layer perceptron as there are 3 stages of neuron processing as we can see between inputs and outputs.

Fuzzy Controllers

Fuzzy control is a methodology to represent and implement a (smart) human's knowledge about how to control a system. A fuzzy controller is shown in Figure 3. The fuzzy controller has several components:

- A rule base that determines on how to perform control
- Fuzzification that transforms the numeric inputs so that the inference mechanisms can understand.
- The inference mechanism uses information about the current inputs and decides the rules that are suitable in the current situation and can form conclusion about system input.
- Defuzzification is opposite of Fuzzification which converts the conclusions reached by inference mechanism into numeric input for the plant.

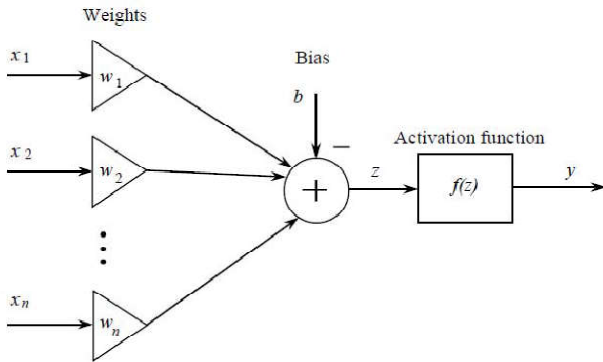

Figure 1. Single Layer Neuron

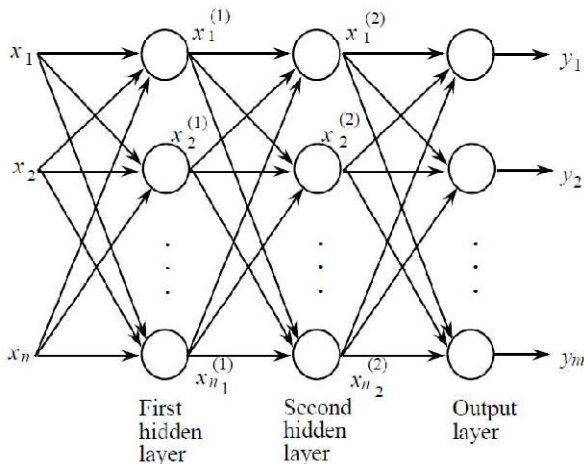

Figure 2. A 3-layer Multi perceptron model

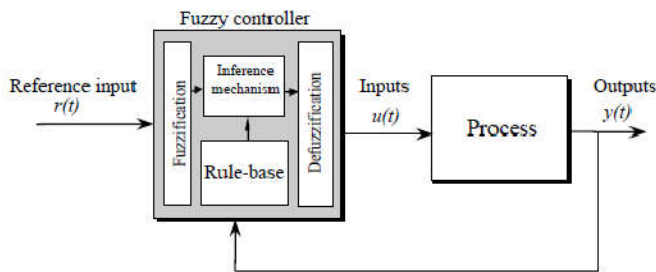

Figure 3. Fuzzy Control System

Expert Systems Control

The Figure 4 below shows how feedback control can be implemented using expert systems. It has a knowledge base which is used by the inference mechanism to decide the input to the system under control. The knowledge base will be typically frames, semantic nets, causal diagrams unlike the IF

THEN statements of fuzzy controllers. The inference strategies are also more elaborate such as refraction, recency, priority.

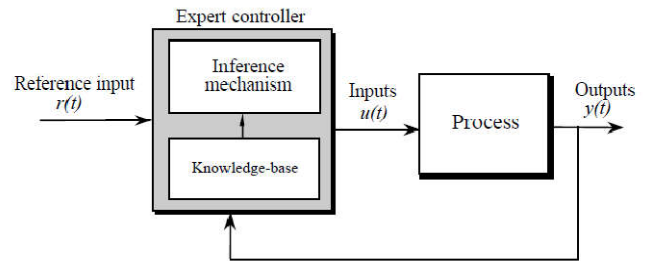

Figure 4. Expert Control System

Planning Systems for Control

The Artificial Intelligence based planning systems are used for robotics for decisions. It can also be configured as a feedback control system as shown in Figure 5 below.

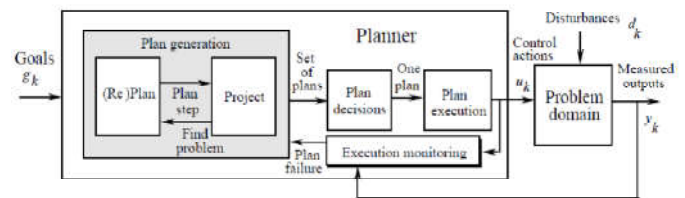

Figure 5. Closed Loop Planning control system

The planner performs plan generation, projecting into future and determines a set of candidate plans. This set of candidate plans is pruned into one plan that is the best one to apply at the current time. The plan is then executed and during execution the performance of that is monitored and evaluated.

Adaptive Control

Adaptive control adapts to the controlled system with parameters which vary or are uncertain. The Figure 6 shows indirect adaptive control. If the plant parameters change the identifier will provide estimates of these and the controller designer will subsequently tune the controller.

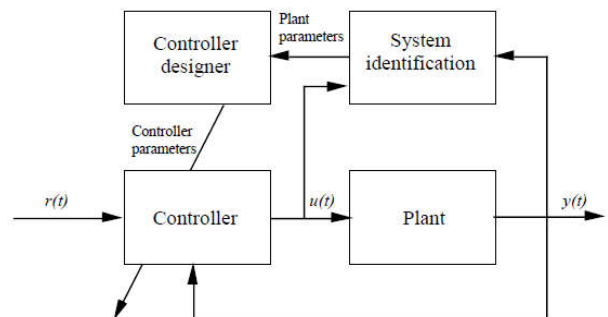

Figure 6. Indirect Adaptive control

The Figure 7 shows direct adaptive control which follows the adaptation mechanism that observes the signals from the control system and adapts the parameters of the controller to maintain performance even if there are changes in the plant.

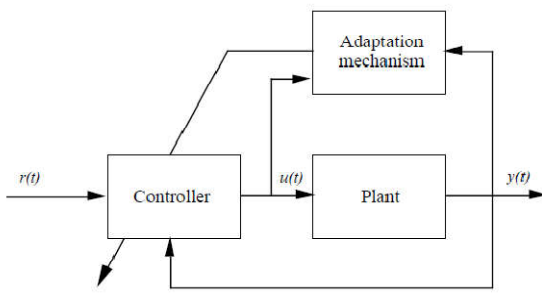

Figure 7. Direct Adaptive control

Intelligent Control applications

In this section we discuss how the intelligent controllers are applied in distributed systems in web server environments, Resource allocation in data centers and admission control of servers.

Web Environments

In this section we discuss the application of intelligent controllers in web based environments. QoS in web environments is an important requirement in distributed systems such as enterprises and internet. There are various investigations in improving the performance of web environments using various techniques. The feedback controllers have been investigated to improve the web server's performance (Gandhi, 2002 and Robertsson, 2004). But the classic controllers will have the challenge of handling the uncertain and non-linear characteristics of the web environments. Intelligent control is the obvious choice to handle the non-linear behaviors. In this section we discuss the applications of intelligent controllers in web environments.

In (Yayawei, 2005), a Fuzzy control based approach is discussed for web servers as they are non-linear and independent of the system model that has to be controlled. The Figure 8 below shows the system architecture using Fuzzy control to manage performance of web server. The Connection scheduler classifies the request that come in to the server based on various parameters like IP address. The monitor measures the absolute delays C_k experienced by the requests of class k . The fuzzy controller guarantees the delay of 8 seconds for the priority class of requests. The error between the measured delay (C_k) and the desired reference delay (DD_k) is the input to the fuzzy controller as shown below. The controller then computes the number of processes that are allocated to each class. The discussed solution is applied in the modified version of Apache server and their results show that using a classical PI Controller linearization degrades the performance of the system. The adaptive fuzzy control adapts to various web servers with speed and thus eliminates the system identification. The results of are not discussed in our review.

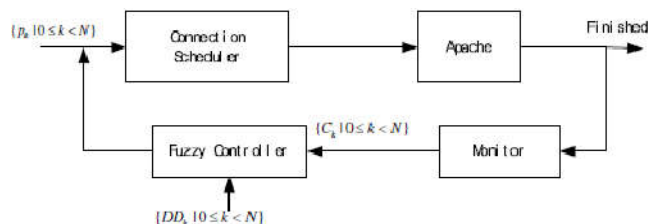

Figure 8. Fuzzy Control of Apache Server

In (FuquanTian, 2010), the web server QoS control is achieved using a hybrid feedback Fuzzy Adaptive PI Controller. The input requests to the web server are adjusted in a control period, and turn down the incoming requests when the server is overloaded. Considering the uncertain dynamics of web environments a fuzzy approach is chosen to tune the PI Controller parameters adaptively.

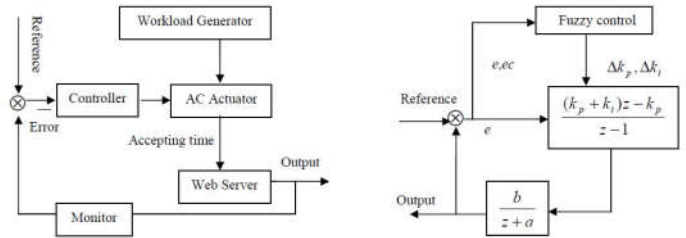

Figure 9. Architecture of ATR Feedback system
Figure 10. Fuzzy adaptive control system

The notion of Accept Time Ratio (ATR) [7] is proposed in the admission control strategy. The Figure 9 shows the ATR feedback control system where the server performance is measured periodically. For every interval the controller computes the next ATR according to the error between the real output and the reference value. Then the request-accepting time t_{admis} computed during which the server accepts requests, and in the remaining of period requests are turn down. The Figure 10 shows the Fuzzy adaptive control system. The value k_p will determine the rapid response of the system and k_i eliminates steady state error. Based on the error e and variance rate ec , the fuzzy control adjusts the values of k_p and k_i to make the controlled system response more rapidly and stably. The Universe of discourse for Δk_p and Δk_i are set to $\{-6, -4, -2, 0, 2, 4, 6\}$. The experiments are based on simulation environment where the basic PI Controller and the discussed Fuzzy Adaptive PI Control are compared on web server, while having fluctuations of load on the server the Fuzzy Adaptive PI Control behaves in a stable manner. We also notice that the adaptive Neuro Fuzzy control techniques are used in web document clustering proposing a framework to personalize e-business processes by adaptive interactive system to customer preferences in [8]. A fuzzy control query language is proposed (fCQL) for analysis and control of business. The details are not discussed here as it is beyond the scope of our review.

Resource Management

Effective utilization of the data center resources despite dynamic and varying load conditions is an important challenge. Typically these variations are non-linear in nature and it is a difficult task to predict the load and keep the resources availability accordingly is a non-trivial task. Provisioning servers for such scenarios is obviously an important problem to solve and in this section we discuss intelligent control approaches that attempt to solve this problem. In [9] an adaptive fuzzy control is proposed to allocate server resources with effective stability in network transfer time or server side request processing time. The controller provides improved client-perceived response time in heavy load web servers. The two different contributions are monitoring and controlling eQoS framework such that the Pageview response time is less and self-tuning Fuzzy Controller (STFC) for resource

allocation within the eQoS framework. The Figure 11 below shows the architecture of the eQoS framework.

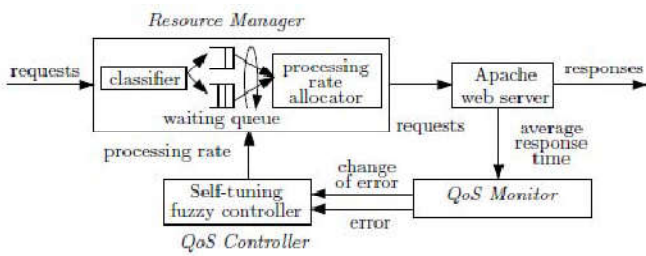

Figure 11. System Architecture of Apache Server STFC

The STFC is shown in Figure 12 below

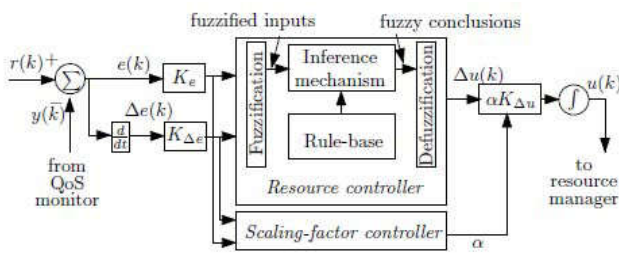

Figure 12. Self tuning Fuzzy Controller

The experimental results show that STFC outperforms the PI Controller. In [10] the authors deal with the non-linear modeling challenges of computing systems and have proposed fuzzy control to minimize the utilization error of the resources in the data center that is adaptive in nature. The Figure 13 shows the closed loop real time system used to run the solution.

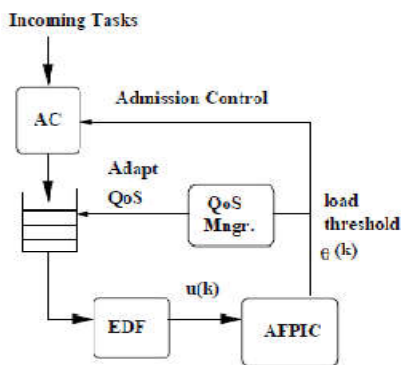

Figure 13.

The real time tasks are scheduled as EDF (earliest deadline first) [11]. The desired utilization factor is U_s , The AFFPIC (Adaptive Fuzzy Proportional Integral Control) computes the acceptable load $\theta(k)$ based on error $e(k)$ and change in the error $\Delta e(k)$ for $u(k)$ measured at k th sampling period.

The error is represented as

$$e(k) = U_s - u(k) \quad (2)$$

$$\Delta e(k) = e(k) - e(k - 1) \quad (3)$$

The Universe of discourse for the utilization factor is $[-1, 1]$ since $e(k) = -1$ if $U_s = 0$ and current utilization $u(k)$ is 1. The Linguistic variables describe the input and outputs of the fuzzy

controller for example two inputs at the k th sampling period are described as error. The Membership Functions for controller input and output $e(k)$, $\theta(k)$, $\Delta e(k)$ at the k th sampling instance are defined in the common normalized domain $[-1,1]$. The Fuzzy utilization control action is characterized into zones shown in Figure 14 below:

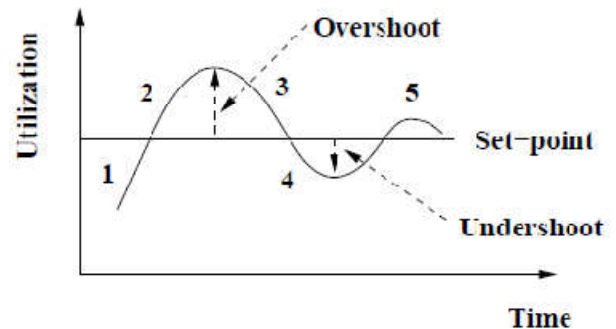

Figure 14 Fuzzy Rule Classification

The discussed Adaptive Fuzzy PI Controller is shown in Figure 15 below:

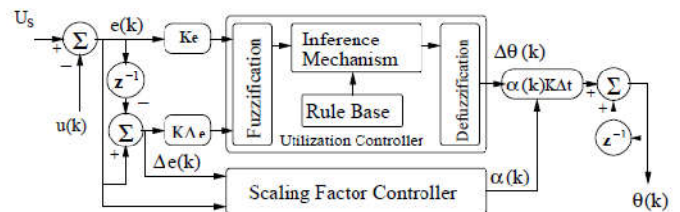

Figure 15. Adaptive Fuzzy PI Controller

The performance of the controller is based on the utilization, success ratio by running simulation tests multiple times and averaging the results. The results between PI Controller, Open loop Fuzzy Logic PI Controller and Adaptive Fuzzy PI Controller (AFPIC) and compared. The convergence for the AFPIC is found to be much faster than other controllers. PI Controller has highest utilization fluctuations. The results discussed show that the adaptive hybrid controllers using the intelligent controls are more effective than the conventional PI controllers. A similar approach is discussed in [12] where a self-adaptive control is proposed that uses the neural network and a fuzzy control. The authors proposed an automatic server allocation approach that uses the end-to-end delay to measure the performance of the predictor in multi-tier server cluster environment. The 95th -percentile end-to-end delay is an important metric to measure in such environments [13]. The fuzzy control is achieved through the heuristics identified by trial and error method and is model independent. But this approach is found to be ineffective under high dynamic load conditions. In order to address the high load and dynamic conditions a hybrid control using machine learning techniques is proposed. The advantage with the hybrid approach is that there is no off-line training, self-construction of the structure, fast learning adapting the parameters through online learning. One of the important measures in multi-tier internet applications is the end-to-end delay The Figure 16 below shows the self-adaptive neural fuzzy control that reduces the end-to-end delay, compensates for the server switching delay. This is used to dynamically provision the server. The controller

adjusts the server provisioning on to bound to 95th –percentile end-to-end delay T_d to a specified target T_{ref} .

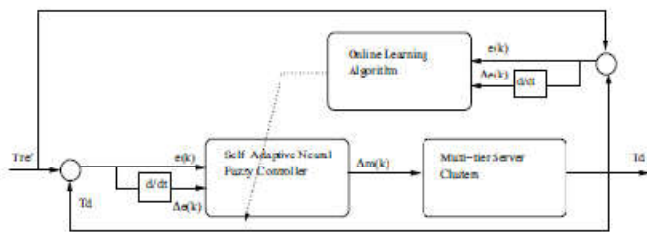

Figure 16. Self adaptive Neuro-Fuzzy Feedback Control system

The Figure 17 below shows how the layers in the neural network used in combination with fuzzy control. The layer 1 node each corresponds to one input. The Layer 2 node acts as linguistic term assigned to one of the input variables. These nodes use the membership functions to determine the degree to which an input belongs to the fuzzy set. In Layer 3 each node represents the precondition part of the fuzzy logic rule. The layer 4 acts a defuzzifier which converts conclusions from layer 3 to numeric output in terms of resource adjustment. The magnitude of the resource adjustment depends upon various parameters and neural fuzzy controller which are determined and adapted using a two phase approach. The structure learning phase decides how to add a new node to layer 2 and parameter learning phase is used adaptively modify the consequent part of existing fuzzy rules to improve controller performance.

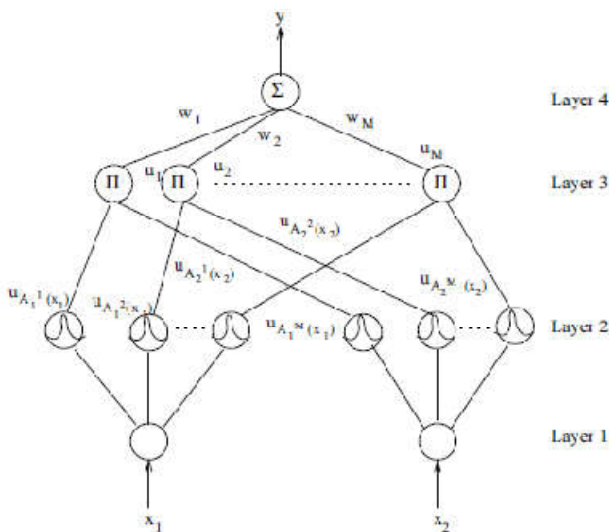

Figure 17. Neuro-Fuzzy Control Schematic diagram

The hybrid self-adaptive neural fuzzy control guarantees the 95th percentile end-to-end delay of requests flowing through a multi-tier cluster. Simulation based experiments are run on the controller. We infer that hybrid controls can be used to predict the server resource requirements of a data center and do resource provisioning appropriately.

Server Admission Control

We have seen so far how Intelligent Controls are applied Web server environments and IT resource provisioning. In this section we discuss how the server admission control through neural network feedback control [14] is achieved, where the

expected load and appropriate resource requirements are predicted much ahead of the time. The server is modeled as a non-linear stochastic single server queuing system. A multi-step ahead auto regressive Neural Network time response predictor is developed. The Figure 18 and Figure 19 below show the single neural network control non-linear predictor and the setup. The predictor is given an offline training where the NE (Node Element) is simulated under high load conditions.

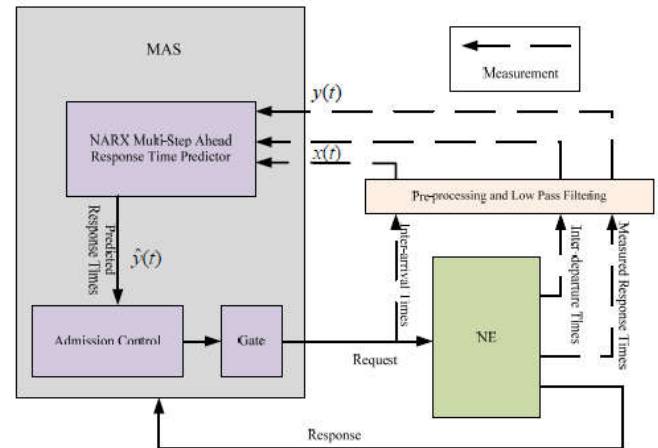

Conclusion and Future work

The survey reveals that the Fuzzy control provides a model independent technique when compared to the classical controllers such as P, PI, PID controllers. Fuzzy control has the capability of handling the non-linear nature of the systems to be controlled. The feedback controllers will be more effective when they are hybrid controllers built using the classic P, PI and PID Controllers and Intelligent controllers such as fuzzy, neural network controllers. Building such hybrid controllers as discussed above are providing encouraging results, based on our study. It is necessary to extend the research of implementing hybrid controllers in distributed systems and other areas of computing that will result in better performance of the systems. We observe that most of the research of applying hybrid controllers in distributed systems such as web servers is verified in simulation environments, but it will be important to study their effectiveness in real distributed systems. Additionally there are many machine intelligence based mechanisms that could be explored further in building effective controllers. Data Mining is combination of various theory and technologies has better algorithms and solutions for prediction, pattern recognition, and can be investigated to build hybrid controllers to build scalable, high performing robust distributed system applications.

REFERENCES

Ali Zilouchian, Mo Jamshidi, 2001. "Intelligent Control Systems using Soft Computing", CRC Press
 FuquanTian, WenboXu, Jun Sun, 2010. "Web QoS Control Using Fuzzy Adaptive PI Controller", Ninth International Symposium on Distributed Computing and Applications to Business, Engineering and Science
 Gandhi, N. and Tilbury, D. M., Diao, Y. 2002. J. Hellerstein, and S. Parekh. "MIMO Control of an Apache Web Server,

- Modeling and Controller Design”, IEEE American Control Conference
- Harkut, D.G. 2011. K.N.Kasat, Dr.S.B.Sadar, 2011. ”Web Document Clustering Adaptive Neuro Fuzzy model”, *International Journal of Advanced Computer Engineering and Architecture*
- JianbinWei, Cheng-ZhongXu, 2006. “eQoS: Provisioning of Client-Perceived End-to-End QoS Guarantees in Web Servers”, IEEE Trans on Computers
- Jiang Ying, and Meng Dan, 2007. “Enforcing Admission Control, Using Admission-Time-Ratio and PI Controller,” *Journal of Computer Research and Development*.
- Kevin, M. Passino, 2001. ”Intelligent Control: An Overview of Techniques”, *Perspectives in Control Engineering: Technologies, Applications, and New Directions*, pp. 104-133, IEEE Press, NY, 2001.
- Mehmet H. Suzer, Kyoung-Don Kang 2008. “Adaptive Fuzzy Control for Utilization Management”, ISORC, Pages 383-390
- Robertsson, A. 2004. B. Wittenmark, M. Kihl, and M. Andersson. “Design and evaluation of load control in web server systems”, IEEE American Control Conference.
- Yayawei, 2005. Chuang Lin, Thiemo Voigt, FengyuanRen, Fuzzy Control for Guaranteeing Absolute Delays in Web Servers”, *QoS in Wireless Networks International Conference*
